



P-NET in building automation

LK A/S Denmark



LK AS

- **Annual turn over 60 Million £**
- **Number of employes: 600**
- **Manufacturing installation material since 1895**
- **Intelligent installation systems since 1987**
- **Market leader in Denmark**
- **Member of LEXEL group of companies**



IHC - Intelligent House Control

- Launched 1993
- No competition in private homes
- Number of nodes installed: approximately 1 million.
- Number of installations: approximately 10.000
- Made for the installer
- Simple and easy programming
- NO configuration (HW addressing)
- High programmability
- Low price per node



IHC Forhandlere

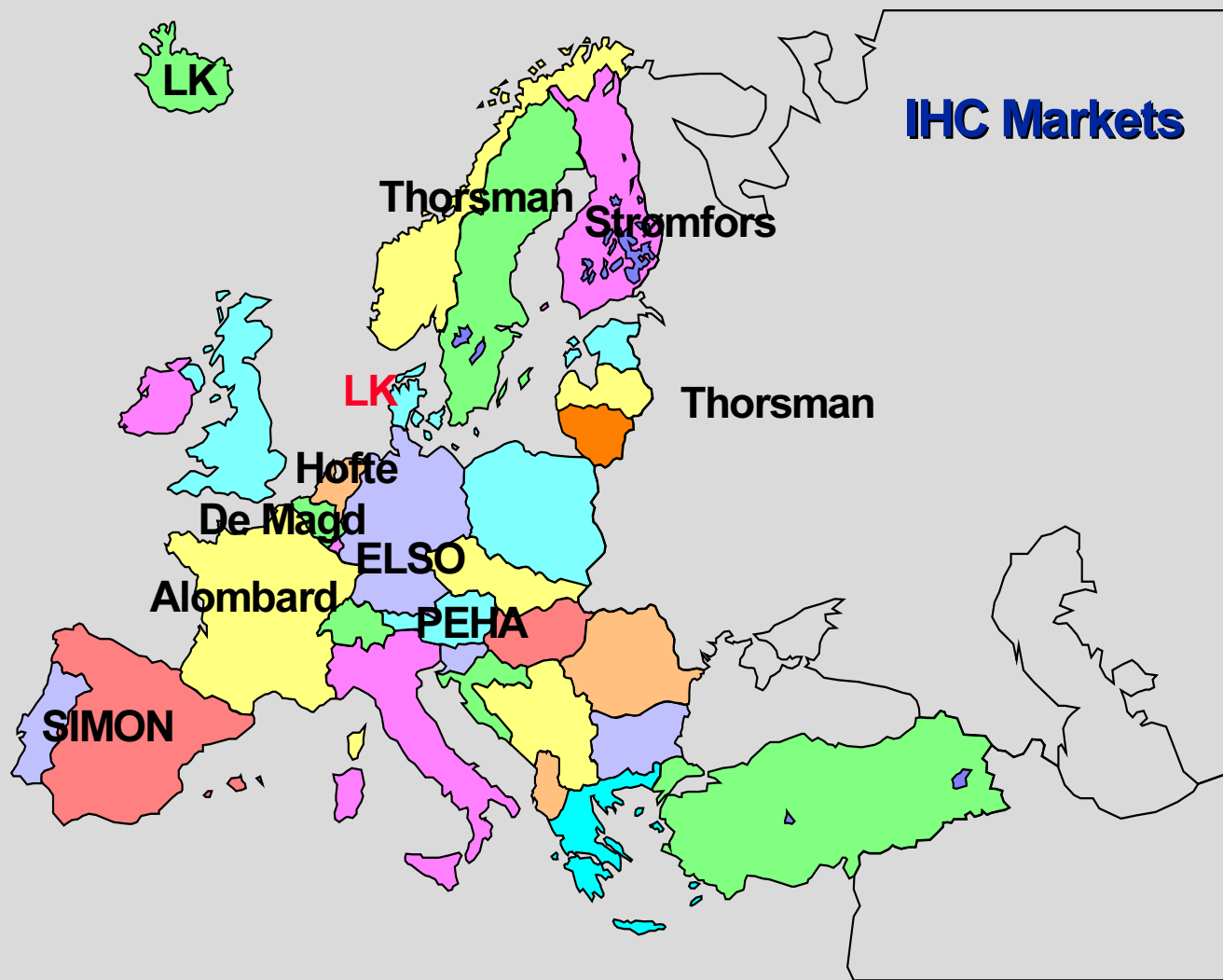



IHC Datalines

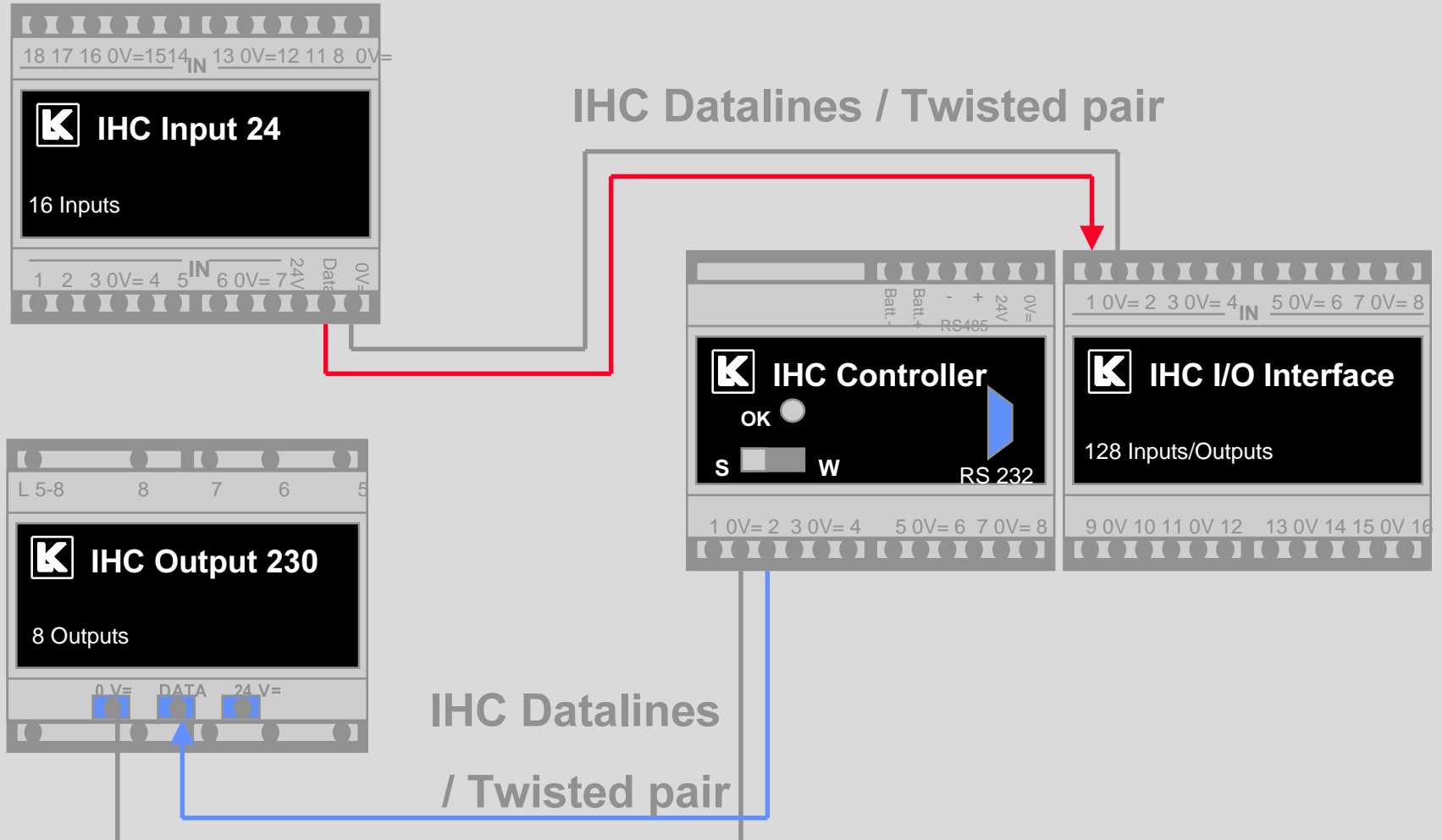



GOAL:

Making larger systems with full functionality possible.



Why we chose Pnet

- **simple IHC-like programming should be possible**
- **simple cabling and interface**
- **easy expandability**
- **proven reliability**
- **standard components available for complex functions**
- **responce times 2-5 seconds**
- **affordable price**



Principle

IHC-BUSlink:

Gateway gives access to controller functions from the network

IHC-BUSlinkMASTER:

Programming like standard IHC with IHC-no. as extension

IHC-BUSlinkMON

Windows based monitoring and control

Max.: 126 units total
32 masters

Software limited to 40 slaves

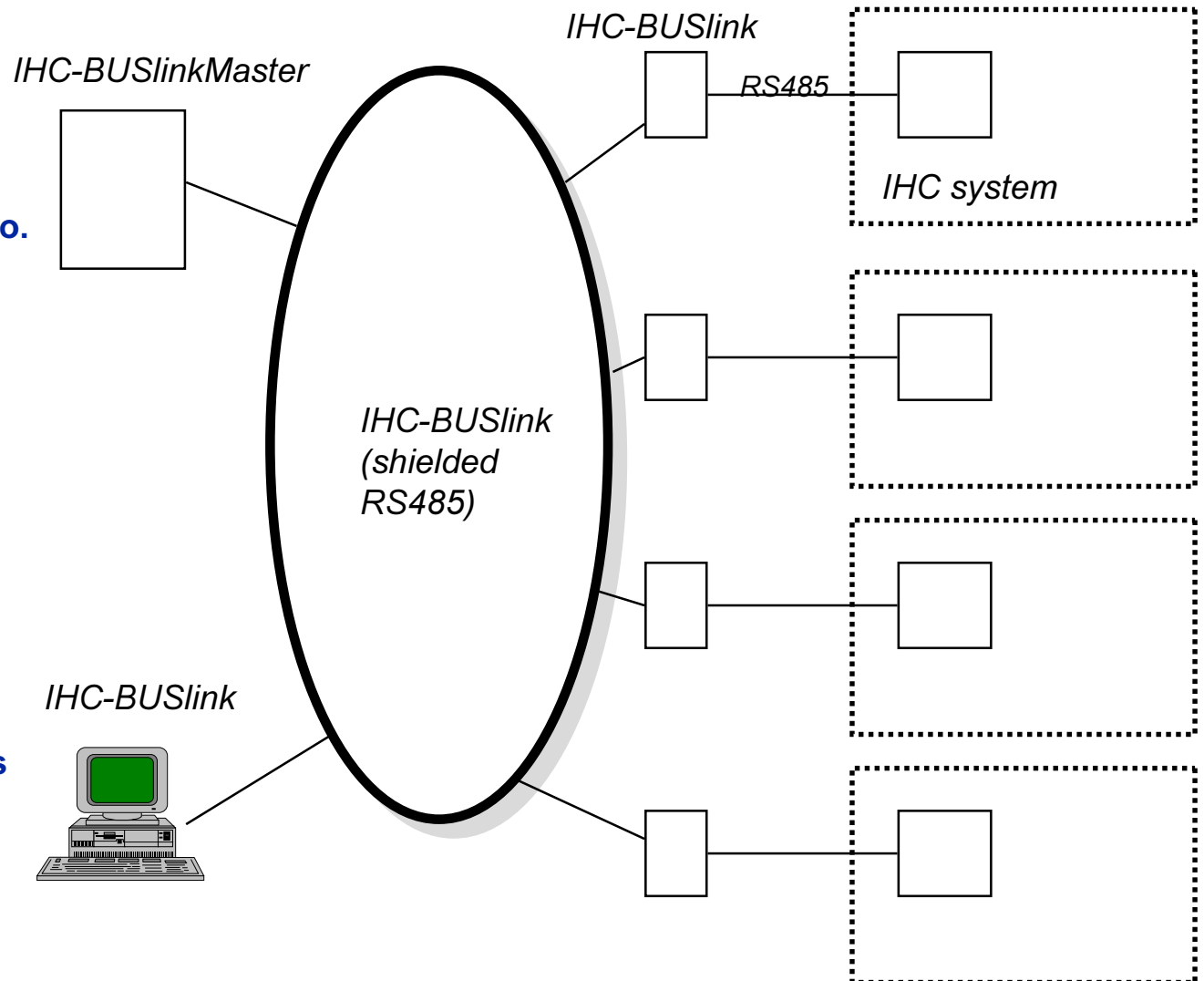



Advantages

- **simple development (Hitachi kit)**
- **standard IHC programming principle**
- **approved, standardised network**
- **simple wiring**
- **easy system expansion**
- **complex functionality via P-net components**
- **outstanding price/performance**



New products:

IHC-Pmaster

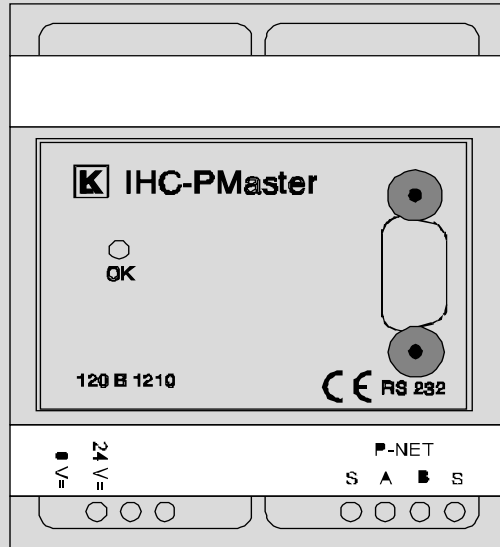

IHC-PNet

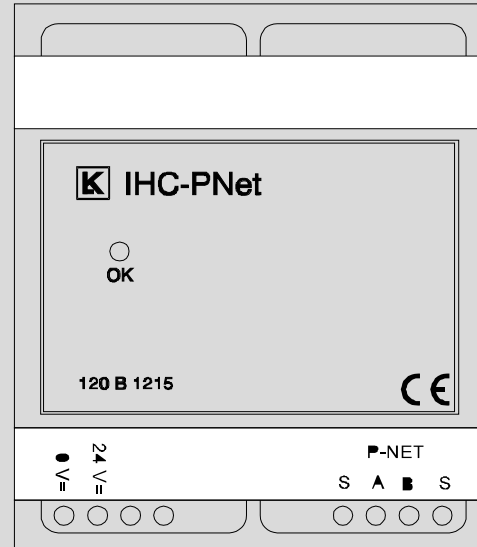

IHC-PMon

Interface : ISA or dongle

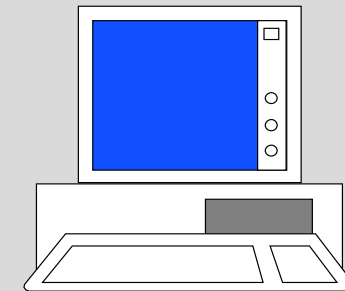

Common data PMaster & PNet

- Power supply: 20-28 V DC
- Current: 40 mA
- Isolation to P-net: 4 KV
- Case: DIN 72

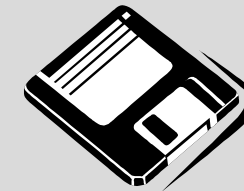



Full graphical monitoring and control

- tools for generating building simulations
- multi tasking and multi driver system
- easy transferral of data and commands between different systems possible
- remote monitoring possible via modem or LAN
- available from LK beginning of 1998